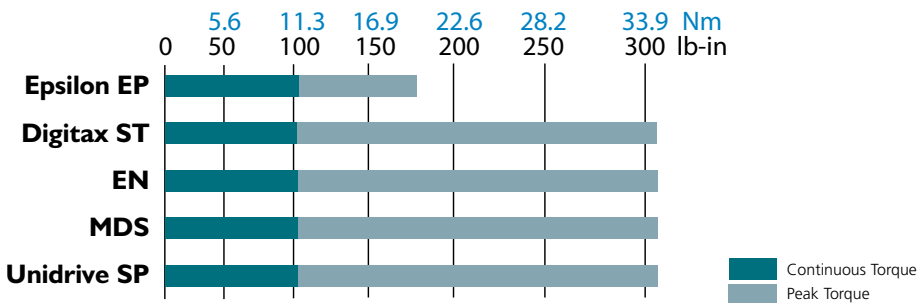

XV—230V

The XV Servo Motor series is a high-performance, low inertia, and high torque in a compact motor package. It offers a low cost solution with the features of a premium priced servo offering. Intended for higher throughputs and smaller machines, XV motors are available in 4 Frame Sizes: 40, 60, 80 and 130 mm with speeds ranging from 2000 to 5000 rpm. Applications with Continuous Torque requirements up to 101 lb-in (11.4 Nm) are the perfect match for the XV motors. XV motors are CE, UL and RoHS approved.

XV

XV Motor Specifications

Motor Model	Rated Torque lb-in Nm	Cont. Stall Current Amps	Peak Current Arms	Motor Resistance Ohms	Motor Inductance mH	Max Operating Speed RPM	Inertia lb-in-sec ² kg-cm ²	Motor Ke Vrms/krpm	Motor Kt lb-in/Arms Nm/Arms	Motor Weight lb kg
XV-401	0.95 0.11	1.07	2.9	11.69	8.54	5000	0.0000097 0.011	7.8	0.89 0.1	0.7 0.3
XV-403	3.09 0.35	1.38	3.8	6.89	6.73	5000	0.00004 0.045	12.7	2.24 0.25	1.1 0.52
XV-606	6.13 0.69	1.63	4.6	4.15	15.21	5000	0.000161 0.182	29.2	3.76 0.43	2.4 1.11
XV-6011	12.0 1.36	2.89	8.3	1.64	7.32	5000	0.000284 0.321	29.5	4.15 0.47	3.5 1.63
XV-8017	17.9 2.0	3.58	10.3	1.43	9.18	5000	0.00096 1.092	35.2	5 0.57	5.4 2.49
XV-8023	24.1 2.73	3.82	11.0	1.29	9.10	3000	0.001335 1.509	44.6	6.32 0.71	6.9 3.15
XV-8028	29.9 3.38	5.37	15.5	0.75	5.04	5000	0.001705 1.927	39.2	5.57 0.63	8.3 3.8
XV-13046	48.4 5.47	6.28	18.5	0.77	7.76	3000	0.010611 11.99	53.1	7.71 0.87	15.8 7.2
XV-13051	53.4 6.04	4.15	12.1	1.87	20.10	2000	0.010611 11.99	85.8	12.87 1.45	15.8 7.2
XV-13068	70.1 7.92	9.23	27.2	0.47	5.27	3000	0.015345 17.34	54.2	7.59 0.86	19.1 8.7
XV-13089	90.0 10.17	5.78	17.2	1.41	15.99	2000	0.015345 17.34	94.6	15.57 1.76	21.3 9.7
XV-130101	101.0 11.41	7.63	22.3	0.87	10.67	2000	0.0200072 22.68	90.0	13.88 1.57	22.4 10.2

Note: Encoder resolution 2048 ppr

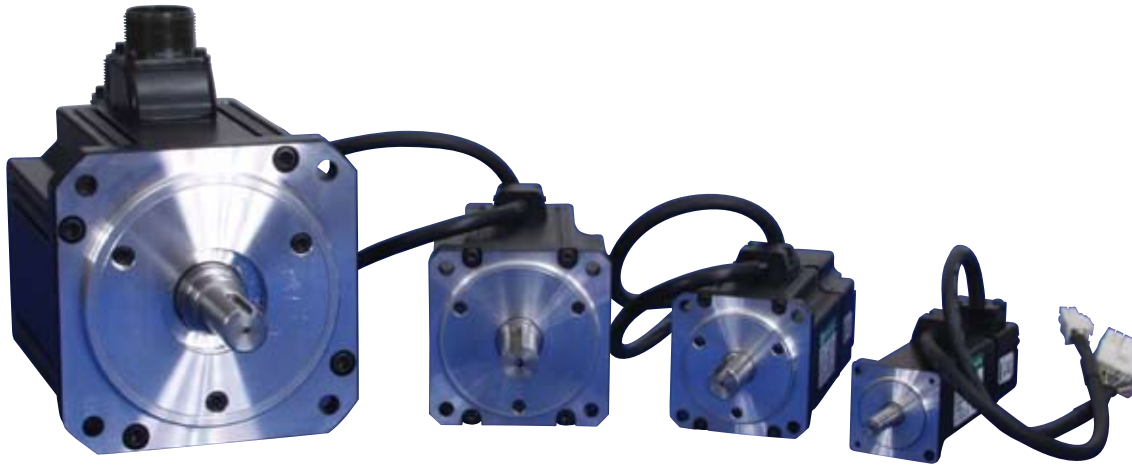

XV Motor Holding Brake Specifications

Motor Frame Size mm	Power Supply DC	Current (A)	Static Torque		Mechanical Engagement Time - Holding Brake ms	Added Inertia		Added weight kg
			lb-in	Nm		lb-in-sec ²	kg-cm ²	
40	24	0.25	2.8	0.318	20	0.0000027	0.003	0.2
60	24	0.27	13.0	1.47	50	0.0000425	0.048	0.6
80	24	0.38	28.6	3.23	60	0.0001106	0.125	0.7
130	24	0.29	70.8	8	40	0.0004779	0.54	0.83

XV Motor IP Ratings

Frame size	IP rating	Exclusions
40 mm	IP55*	Shaft through area of face plate and connectors
60 mm	IP55*	Shaft through area of face plate and connectors
80 mm	IP65*	Shaft through area of face plate and connectors
130 mm	IP65*	shaft through area of face plate

* Shafts are not fitted with seals

Thermal Protection

The XV motors do not have and are not offered with a winding thermal temperature sensor. Motor feedback cables have the Motor Temperature Sensor lines defeated (shorted between pin 14 (DNG) and pin 15 (5V)). These cables include cable model numbers: XUFTS-xxx and XUFCS-xxx (XEFTS-xxx and XEFCS-xxx).

All of the servo drives offered by Control Techniques have a current limiting algorithm in the firmware specifically to limit current levels. When properly matched and limited to the motor specifications the drive firmware will fault the drive when the rated RMS current of the motor is exceeded.

- Ambient operating temperature: 0° to 40° Celsius
- Storage Temperature: -20° to 80° Celsius
- Atmosphere: No corrosive gas, flammable gas, oil mist, or dust

XV Motor Dimensions Table

Inches (mm)	40mm		60mm	
	XVM-401	XVM-403	XVM-606	XVM-6011
A Length Overall - CONS (Max)				
A Length Overall - TONS (Max)	2.980 (75.7)	3.917 (99.5)	4.173 (106)	5.276 (134)
A Length Overall - CBNS (Max)				
A Length Overall - TBNS (Max)	4.409 (112)	5.354 (136)	5.748 (146)	6.850 (174)
B Flange Square	1.575 (40)	1.575 (40)	2.44 (62)	2.44 (62)
C Flange Thickness	0.197 (5)	0.197 (5)	0.236 (6)	0.236 (6)
D Pilot Diameter	1.181 (30)	1.181 (30)	1.969 (50)	1.969 (50)
E Pilot Thickness	0.098 (2.5)	0.098 (2.5)	0.118 (3)	0.118 (3)
F Bolt Hole Diameter	0.177 (4.5)	0.177 (4.5)	0.236 (6)	0.236 (6)
G Bolt Circle Diameter	1.811 (46)	1.811 (46)	2.756 (70)	2.756 (70)
H Signal Connector Height - CONS (Max)				
H Signal Connector Height - TONS (Max)	1.220 (31)	1.220 (31)	1.732 (44)	1.732 (44)
H Signal Connector Height - CBNS (Max)				
H Signal Connector Height - TBNS (Max)	1.220 (31)	1.220 (31)	1.732 (44)	1.732 (44)
I Shaft Length	0.984 (25)	0.984 (25)	1.181 (30)	1.181 (30)
J Shaft Diameter	0.315 (8)	0.315 (8)	0.551 (14)	0.551 (14)
Shaft key Dimensions				
K Keyway Length (Min)			0.886 (22.5)	0.886 (22.5)
L Keyway Depth			0.118 (3)	0.118 (3)
M Keyway Width			0.197 (5)	0.197 (5)

Inches (mm)	80mm			130mm				
	XVM-8017	XVM-8023	XVM-8028	XVM-13046	XVM-13051	XVM-13068	XVM-13089	XVM-130101
A Length Overall - CONS (Max)				6.614 (168)	6.614 (168)	7.559 (192)	7.559 (192)	8.501 (216)
A Length Overall - TONS (Max)	5.433 (138)	6.220 (158)	7.008 (178)					
A Length Overall - CBNS (Max)				8.110 (206)	8.110 (206)	9.055 (230)	9.055 (230)	10.00 (254)
A Length Overall - TBNS (Max)	7.008 (178)	7.795 (198)	8.583 (218)					
B Flange Square	3.150 (80)	3.150 (80)	3.150 (80)	5.118 (130)	5.118 (130)	5.118 (130)	5.118 (130)	5.118 (130)
C Flange Thickness	0.433 (11)	0.433 (11)	0.433 (11)	0.551 (14)	0.551 (14)	0.551 (14)	0.551 (14)	0.551 (14)
D Pilot Diameter	2.756 (70)	2.756 (70)	2.756 (70)	4.331 (110)	4.331 (110)	4.331 (110)	4.331 (110)	4.331 (110)
E Pilot Thickness	0.118 (3)	0.118 (3)	0.118 (3)	0.236 (6)	0.236 (6)	0.236 (6)	0.236 (6)	0.236 (6)
F Bolt Hole Diameter	0.260 (6.6)	0.260 (6.6)	0.260 (6.6)	0.354 (9)	0.354 (9)	0.354 (9)	0.354 (9)	0.354 (9)
G Bolt Circle Diameter	3.543 (90)	3.543 (90)	3.543 (90)	5.709 (145)	5.709 (145)	5.709 (145)	5.709 (145)	5.709 (145)
H Signal Connector Height -CONS (Max)				4.409 (112)	4.409 (112)	4.409 (112)	4.409 (112)	4.409 (112)
H Signal Connector Height -TONS (Max)	2.087 (53)	2.087 (53)	2.087 (53)					
H Signal Connector Height -CBNS (Max)				4.409 (112)	4.409 (112)	4.409 (112)	4.409 (112)	4.409 (112)
H Signal Connector Height -TBNS (Max)	2.087 (53)	2.087 (53)	2.087 (53)					
I Shaft Length	1.575 (40)	1.575 (40)	1.575 (40)	2.283 (58)	2.283 (58)	2.283 (58)	2.283 (58)	2.283 (58)
J Shaft Diameter	0.630 (16)	0.630 (16)	0.630 (16)	0.748 (19)	0.748 (19)	0.866 (22)	0.866 (22)	0.866 (22)
Shaft key Dimensions								
K Keyway Length (Min)	1.181 (30)	1.181 (30)	1.181 (30)	0.984 (25)	0.984 (25)	0.984 (25)	0.984 (25)	0.984 (25)
L Keyway Depth	0.118 (3)	0.118 (3)	0.118 (3)	0.118 (3)	0.118 (3)	0.138 (3.5)	0.138 (3.5)	0.138 (3.5)
M Keyway Width	0.197 (5)	0.197 (5)	0.197 (5)	0.197 (5)	0.197 (5)	0.236 (6)	0.236 (6)	0.236 (6)

XV MOTOR DIMENSIONS

Fly lead length 12" on 40mm, 60mm and 80mm

TONS
TBNS

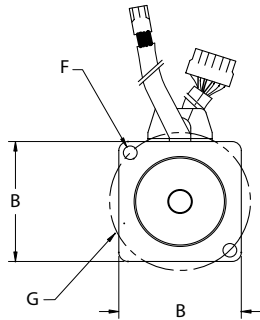

PLUG: AMP 172167-1
mating connector - Amp
housing - 172159-1
pins - 170362-1

PLUG: AMP 172165-1
mating connector - Amp
housing - 172157-1
pins - 170362-1

PLUG: AMP 172171-1
mating connector - Amp
housing - 172163-1
pins - 170361-1

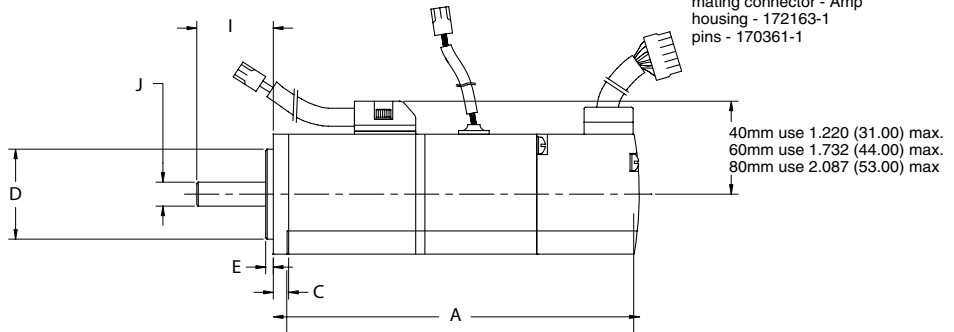

CONS
CBNS

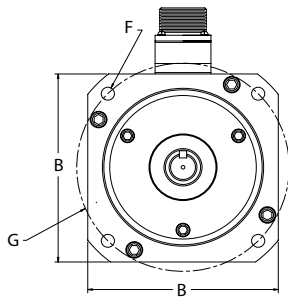

Connector standard: MS3102A20-4P
Mating Connector: Amphenol MS3106A-20-4S
Connector brake: MS3102A20-15P
Mating Connector: Amphenol MS3106A-20-15S

Connector: MS3102A20-29P
Mating Connector: Amphenol 973106A-20-298

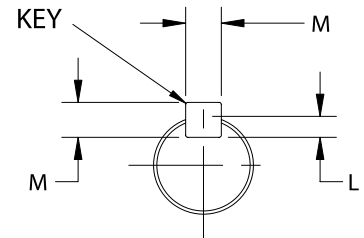
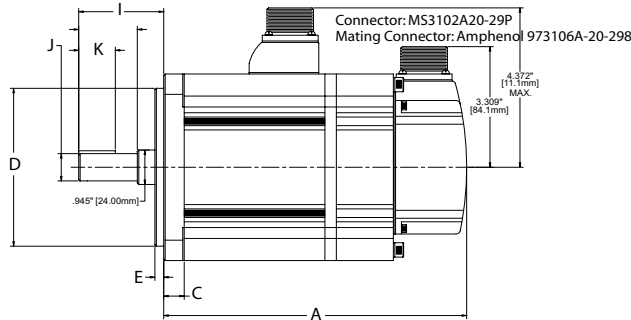

40 mm motor has no key way

The dimensional information found on these pages is not to be used for design purposes. For complete engineering controlled drawings, please refer to the web site or Power CD.

Go to
Power CD
for complete data