

Connectivity

Choose the Fieldbus that fits you AND your application.

At Control Techniques, we recognize the importance of simplicity in fieldbus communications. Incorporating a vast range of fieldbus options onto our drives has been an important step in making system configuration and troubleshooting quick and easy. From Solutions Modules (SM's), to Function Modules (FM's), to built in drive communications, Control Techniques offers our customers fieldbus solutions that are so flexible and easy that some customers have used drives as network gateways! A wide array of communications options are available for your application:

MODBUS



CAN



INTERBUS

MODBUS TCP/IP



Choose your master controller, choose your fieldbus of choice, and then choose the most flexible drives available, Control Techniques.



HOW DOES A FIELDBUS WORK?

Fieldbus networks exchange data using one of two methods. Cyclic or Acyclic data. Cyclic data is information that is pre-configured to pass from one device to another at a known rate. Cyclic data is expected on both the sender and the receiver end of the message, therefore if this cyclic data is not delivered with the proper timing, faults will occur on the network that may be monitored for reliability assurance.

Acyclic messages are messages that are sent and received at any time as they are generated by the sender. Acyclic messages generally have a lower priority than cyclic messages and they incorporate a "request" and "response" communications scheme where the message sender waits to receive a response from the target before generating another message. This response tells the sender whether or not the message was successfully transmitted over the network.

MODBUS RTU

Modbus RTU (Remote Terminal Unit) is the Control Techniques standard for serial communications. Initially developed for Modicon PLC communications, Modbus RTU has grown into an industrial automation standard supported by most PLC and HMI manufacturers. Modbus uses an acyclic message structure to allow access to all drive parameters. Modbus RTU comes standard on nearly all Control Techniques' drive products making integration with other devices simple and seamless.

Commander SK

- Access to all menu parameters
- Multidrop drives easily using RJ45-5
- Baud rates up to 38.4 k baud

Commander GP20

- Access to all menu parameters
- Multi-drop drives easily using RJ45-5
- Baud Rates up to 115.2K baud

Unidrive SP / Digitax ST

- Access to all menu parameters
- Modbus RTU through comm. port on SM-Applications Plus module
- Modbus master capabilities with an SM-Applications Plus module
- Multi-drop drives easily using RJ45-5
- Baud rates up to 115.2 k baud



Commander SK showing connection to the serial port

Epsilon EP / FM-3 / FM-4

- Fully configurable Modbus mappings (via PowerTools Pro)
- All user parameters accessible
- Drag and Drop Modbus configuration

Epsilon EP-B / Epsilon EP-I / FM-2 / EN / MDS

- Preconfigured Modbus registers
- Access to all user parameters

Quantum/Mentor

- MD-29 required
- Rates up to 38.4 K band

Modbus

Drive	Hardware	Parameter Access	Serial Type	Network Operation	Cyclic Data Size	Acyclic Data
Commander SX	Built in	Full	RS485	Follower	N/A	Yes
Commander SK	Built in	Full	RS485	Follower	N/A	Yes
Commander GP20	Built in	Full	RS485	Follower	N/A	Yes
Unidrive SP	Built in	Full	RS485	Follower	N/A	Yes
Unidrive SP	SM-Applications Plus	Full	RS485	Master/Follower	N/A	Yes
Digitax ST	Built in	Full	RS485	Follower	N/A	Yes
Epsilon EP	Built in	Full	RS485	Follower	N/A	Yes
EN	Built in	Full	RS232/RS485	Follower	N/A	Yes
MDS	Built in	Full	RS232/RS485	Follower	N/A	Yes
FM-2	Built in	Full	RS232/RS485	Follower	N/A	Yes
FM-3(DN,PB,E)	Built in	Full	RS232/RS485	Follower	N/A	Yes
FM-4(DN,PB,E)	Built in	Full	RS232/RS485	Follower	N/A	Yes
Mentor	9729-9000 (MD-29)	Full	RS485	Follower	N/A	Yes
Quantum	9729-9000 (MD-29)	Full	RS485	Follower	N/A	Yes

MODBUS TCP/IP

Ethernet communications has migrated from the office floor to the plant floor providing a new level of networking control and flexibility that can be extended across an entire company and the globe. Our Ethernet connectivity offering is feature packed, but you don't need to be an IT professional to understand it. Control Techniques makes Ethernet communications easy.

Unidrive SP / Digitax ST Commander GP20 / Commander SK

- Ethernet/IP
- Modbus TCP/IP support
 - Access to all parameters
- 10/100 Mb/s auto-negotiation, auto cross-over protection
- HTTP Web Server allows full access to drive configuration
- Superior security features
- User created/defined web page capabilities
- FTP Upgrade capabilities
- Remote Programming Options
 - CTSOft
 - CTScope
 - SyPTLite
 - SyPTPro (Unidrive SP only)
 - PowerTools Pro (Unidrive SP only)
 - CT OPC Server

Epsilon EP-P / FM-3E / FM-4E

- Modbus TCP/IP Support
 - Access to all parameters
- EtherNet/IP Support
 - Up to 122 words produced
 - Up to 122 words consumed
- 10/100 Mb/s auto-negotiation
- HTTP Web Server allows access to select parameters
- Remote Programming Options
 - PowerTools Pro

Drive	Required Modules	Network Operation	Hardware	Ethernet/IP Cyclic Data Access	Ethernet/IP Non-cyclic Messaging	Modbus TCP/IP
Commander SX	SM-Ethernet	Follower	RJ-45	Yes	Yes	Yes
Commander SK	SM-Ethernet	Follower	RJ-45	Yes	Yes	Yes
Commander GP20	SM-Ethernet	Follower	RJ-45	Yes	Yes	Yes
Unidrive SP	SM-Ethernet	Follower	RJ-45	Yes	Yes	Yes
Epsilon EP-P	None	Follower / Peer to Peer	RJ-45	122 Words IN / Out	Yes	Yes
EN	FM-3/4E					
MDS	FM-3/4E					

DeviceNet is a high speed communications network protocol that uses Controller Area Network (CAN) hardware layer and signaling. The CAN hardware layer specifies a 5 wire connection and includes 24 Volts between two of these wires. Supported baud rates include: 125 k, 250 k, and 500 k baud. DeviceNet networks require a master controller usually a PLC "scanner" with all network communications controlled by the master device.

Unidrive SP / Digitax ST Commander GP20 / Commander SK

- Access to all menu parameters
- Polled I/O 28 words IN / 28 words OUT (Cyclic data)
- Explicit Message Support for all parameters

FM-3 / 4DN

- Polled I/O connection support (Cyclic data)
- Drag and Drop DeviceNet Configuration
- Explicit Messaging (Acyclic data)

Epsilon EP-IDN, EP-PDN

- Polled I/O connection support (Cyclic data)
- Explicit Messaging (Acyclic data)

Quantum / Mentor

- Access to all user parameters
- Polled I/O support (Cyclic data)
- Explicit message support
- MD-25 required

Drive	Required Modules	Network Operation	Cyclic Data Access	Explicit Messaging Access
Commander SX	SM-DeviceNet	Follower	28 Words IN / 28 Words Out	Yes
Commander SK	SM-DeviceNet	Follower	28 Words IN / 28 Words Out	Yes
Commander GP20	SM-DeviceNet	Follower	28 Words IN / 28 Words Out	Yes
Unidrive SP	SM-DeviceNet	Follower	28 Words IN / 28 Words Out	Yes
Epsilon EP-IDN	N/A	Follower	4 Words IN / 4 Words Out	Yes
EN	FM-3/4DN	Follower	12 Words IN / 12 Words Out	Yes
MDS	FM-3/4DN	Follower	12 Words IN / 12 Words Out	Yes
Mentor II	MD25	Follower	3 Words IN / 3 Words Out	Yes
Quantum III	MD25	Follower	3 Words IN / 3 Words Out	Yes

EtherCAT

EtherCAT slave option module for high performance servo applications. EtherCAT is a real time industrial Ethernet fieldbus. The bus system modifies the standard Ethernet hardware and uses a bus type structure to pass the data from device to device. Protocol efficiencies are gained by embedding the data for many devices within one Ethernet frame obtaining 90% efficiency from the available bandwidth.

EtherCAT is an open, real-time industrial Ethernet solution using modified Ethernet hardware and a pass through type packet that allows extremely fast and deterministic update rates.

The SM-EtherCAT module is for use with Control Techniques' Commander SK, Commander GP20, Unidrive SP, and Digitax ST drives.

The SM-EtherCAT module can read and write cyclic data of five, 32 bit drive parameters every 250 μ s, synchronizing the drive's position or speed loop with the communications network and improving overall system performance.

Unidrive SP / Digitax ST Commander GP20 / Commander SK

- Up to 64535 nodes on a segment
- Data rate of 100 Mbps (100 BASE-TX)
- Update 40 axes in 200 μ s (assuming 2 words command data and 3 words feedback data per axis, a control word and basic cyclic synchronisation data)
- Jitter of less than 1 μ s (less than 500 ns with Unidrive SP 3, 6 and 12 kHz switching frequencies)
- Non-cyclic data using the CoE mailbox
- CANopen DS-402 profile supported (drives and motion control)
- Non-cyclic data can be realized using CoE
- The DSP-402 profile for motion control and drives is supported
- 2 RJ45 ports

Drive	Required Modules	Network Operation
Commander SK	SM-EtherCAT	Follower
Commander GP20	SM-EtherCAT	Follower
Unidrive SP	SM-EtherCAT	Follower
Digitax ST	SM-EtherCAT	Follower





Profibus-DP is a high speed communications network protocol that allows large amounts of data to be transferred quickly (up to 12 MB/s). The Profibus-DP interface detects the network data rate and automatically synchronizes to it. Profibus-DP systems are centralized and consist of a master controller controlling all communications with follower nodes on the network.

**Unidrive SP / Digitax ST
Commander GP20 / Commander SK**

- Access to all user parameters
- Cyclic I/O 32 words IN / 32 words OUT
- Non-cyclic Message Support for all parameters
- DPV0, DPV1 functionality including Profidrive profile support

Epsilon EP-PB / FM-3PB / FM-4PB

- Cyclic I/O connection support
- Drag and Drop DeviceNet Configuration
- Non-cyclic Message Support

Quantum / Mentor

- Access to all parameters
- Cyclic I/O support
- MD-24 required

Drive	Required Modules	Network Operation	Cyclic Data Access	Non-cyclic Messaging Access
Commander SK	SM-Profibus	Follower	32 Words IN / 32 Words Out	Yes
Commander GP20	SM-Profibus	Follower	32 Words IN / 32 Words Out	Yes
Unidrive SP	SM-Profibus	Follower	32 Words IN / 32 Words Out	Yes
Digitax ST	SM-Profibus	Follower	32 Words IN / 32 Words Out	Yes
Epsilon EP-PB	None	Follower	12 Words IN / 12 Words Out	Yes
EN	FM-3/4PB	Follower	12 Words IN / 12 Words Out	Yes
MDS	FM-3/4PB	Follower	12 Words IN / 12 Words Out	Yes
Mentor II	MD24	Follower	4 Words IN / 4 Words Out	Yes
Quantum III	MD24	Follower	4 Words IN / 4 Words Out	Yes



The SM-SERCOS module is class B compliant, supporting the torque, velocity and position control modes. This flexible module also supports probing cycle additional functions (Position registration) and user-defined telegrams.



The SM-SERCOS module is configurable through Unidrive SP parameters — there are no hardware configuration switches.

The SM-SERCOS module uses the standard fibre optic ring topology, using standard transmit and receive optical connectors.

- All SERCOS baud rates supported — (16 Mbps Default), 8 Mbps, 4 Mbps, 2 Mbps.
- Network cycle times support: 250 µs, 500 µs and 1 to 65 ms (In 1 ms increments).
- Four optical power levels are available for transmission, and it is possible to disable the network repeater in the module (breaking the network at the point).
- Provides two freeze inputs used for SERCOS probing cycle functionality.

Drive	Required Modules	Network Operation	Cyclic Data Access	Acyclic Messaging Access
Unidrive SP	SM-SERCOS	Follower	Closed Loop Data	Yes
Digitax ST	SM-SERCOS	Follower	Closed Loop Data	Yes



The CANopen interface has been tested and awarded full Product Conformance Certification by CiA (CAN In Automation), the controlling body for CANopen. Conveniently, the CANopen interface is configured as a slot-in card to the interface module which gives the Unidrive SP its flexibility in high level control and communication systems.

The CANopen interface enables OEMs and users to harness the comprehensive facilities of CANopen for use in industrial automation systems where Unidrives may be called upon to network with other CANopen compliant “intelligent” devices such as sensors and actuators.

It allows process data to be regularly updated in remote network nodes, and removes the need for extensive digital and analog I/O wiring. Supported data rates for CANopen range from 10 K bits/sec to 1 M bit/sec.

Drive	Modules	Network Operation	Cyclic Data Access	Acyclic Messaging Access
Commander SX	SM-CANopen	Follower	4 Words IN / 4 Words Out	Yes
Commander SK	SM-CANopen	Follower	4 Words IN / 4 Words Out	Yes
Commander GP20	SM-CANopen	Follower	4 Words IN / 4 Words Out	Yes
Unidrive SP	SM-CANopen	Follower	4 Words IN / 4 Words Out	Yes
Digitax ST	SM-CANopen	Follower	4 Words IN / 4 Words Out	Yes

CAN INTERFACE

The Unidrive SP SM-CAN interface allows any CAN protocol to be implemented for Unidrive using DPL (Drive Programming Language) code or the Function Block Editor within SyPTPro (System Programming Tool). Function blocks are available for the SyPTPro Workbench that provide full access to the CAN controller from the DPL program.

Due to the way CAN works, it is ideal for designing and implementing networks with “peer-to-peer” communications, where nodes are allowed to transmit data over the network at data rates from 10K bits/sec to 1 M bit/sec, without the need for an overall master controller.

The CAN controller used in the Unidrive SP CAN module has full message filtering features built in, which allows the CAN controller to filter out unwanted messages, thus reducing the loading on the CPU.

Drive	Required Modules	Network Operation	Cyclic Data Access	Acyclic Messaging Access
Unidrive SP Digitax ST-P	SM-CAN*	Master/ Follower	User Configurable	User Configurable

*Also requires SM-Applications Plus module

INTERBUS-S

Interbus-S networks are ‘centralized’ systems, requiring a master controller (usually a PLC) which controls all communications with follower nodes on the network. The Interbus-S interface enables the drive to function as these network nodes, with the advantage for users that it does not require any change to its default setting to operate on a configured network.

The master controller scans the network during network initialization, and assigns addresses to each node depending on their physical location on the network. The data rate for Interbus-S is fixed at 500 K bit/sec.

Drive	Modules	Network Operation	Cyclic Data Access	Non-cyclic Messaging Access
Commander SX	SM-INTERBUS	Follower	10 Words IN / 10 Words Out	Yes
Commander SK	SM-INTERBUS	Follower	10 Words IN / 10 Words Out	Yes
Commander GP20	SM-INTERBUS	Follower	10 Words IN / 10 Words Out	Yes
Unidrive SP	SM-INTERBUS	Follower	10 Words IN / 10 Words Out	Yes
Digitax ST	SM-INTERBUS	Follower	10 Words IN / 10 Words Out	Yes
Mentor II	MDIBS	Follower	3 Words IN / 3 Words Out	Yes
Quantum III	MDIBS	Follower	3 Words IN / 3 Words Out	Yes



Highly Deterministic Distributed Control

Control Techniques CNet interface enables users to leverage the facilities of the Unidrive SP and Mentor II, Applications coprocessor modules, for real time decentralized control. CNet was developed specifically for highly dynamic applications, over trunk lengths generally exceeding 100 m, using proven token ring data link technology. CNet is a “decentralized peer-to-peer” system, requiring no master PLC controller, with each intelligent node taking its turn to control the network, and communicate directly, and in real-time, with other network nodes at data transfer rate of up to 5 M bits/sec. CNet supports up to 255 nodes and provides an intelligent drive-oriented approach to systems integration based on decentralized control, universal communications and graphical software.

Unidrive SP / Digitax ST enable a CNet gateway to industrial networks such as Profibus-DP, Interbus-S, DeviceNet, Ethernet, and SERCOS.

Drive	Modules	Parameter Access	Hardware	Cyclic Data Size	Non-cyclic Messaging Access
Unidrive SP	SM-Applications Plus	Full	ARCNET	N/A	Yes
Digitax ST-P	Integrated	Full	ARCNET	N/A	Yes
Mentor II	MD-29AN	Full	ARCNET	N/A	Yes
Quantum III	MD-29AN	Full	ARCNET	N/A	Yes

Drive Integration with CTNet

Decentralized Control Solution

CTNet is a comprehensive line of equipment enabling the design engineer to create high performance and cost effective decentralized control solutions. The CTNet product range supports intelligent co-processors installed in Control Techniques' AC and DC drives with a high-speed peer-to-peer fieldbus that enables the control set up required by an application distributed.

The CTNet fieldbus is a 5 Mbit token ring network that supports peer-to-peer communications. Utilizing the field-proven ANSI/ATA 878.1 ARCNET standard as a foundation, CTNet includes a custom protocol stack that supports cyclic data and non-cyclic "one shot" transactions. The CTNet fieldbus employs an RS485 transformer-isolated physical layer to allow usage of a convenient and inexpensive two-wire shielded, non-phasic cable.

Two methods of data exchange are supported: cyclic data and Acyclic data. Cyclic data exchanges are pre-programmed block transfers (20 registers max.) between coprocessors at either a fast or slow rate. Acyclic exchanges are asynchronous transfers initiated by application programs or SCADA / HMI devices.

CTNet is used in conjunction with SyPTPro programs.



CTNET INTERGRATION AT-A-GLANCE

Function	Description	Order Code
Application Co-processor Modules	Includes CTNet fieldbus connections & Co-processor	SM-Applications Plus (Unidrive SP & Digitax ST-P), MD29AN RevD* (Mentor)
Network Accessories	3 port Hub, provides Connectivity to 3 CTNet segments	CTNet-Hub-RevD*
	Fibre optic Repeater	CTNet-FIB-RevD*
	3 port Hybrid Hub, for connectivity between current and previous CTNet versions	CTNet-Hybrid-Hub
	CTNet bulk cable	CTNet-XXX
PC Network Card	USB22-CTNet - Computer USB port to CTNet communications interface	4500-0100
Remote I/O	Beckhoff bus coupler	SSP7200-RevD
HMI Display Operator Interface	Operator Interface Unit	CTIU200
	CTNet comms card	CTIU200-CTnet-RevC
Application Programming Software	Systems Programming Toolkit	SYPTPRO
Power Supply	24 VDC Power Supply	Consult Drive Center
Network Bridges	Bridge between CTNet and DeviceNet, PROFIBUS DP, INTERBUS, Modbus, Sercos, Ethernet, and CANopen	Unidrive SP (Gateway Feature)

* CTNet components sold prior to January 2003 utilizes a different product revision than shown above, Rev D. Please contact Control Techniques when purchasing components for older installations.

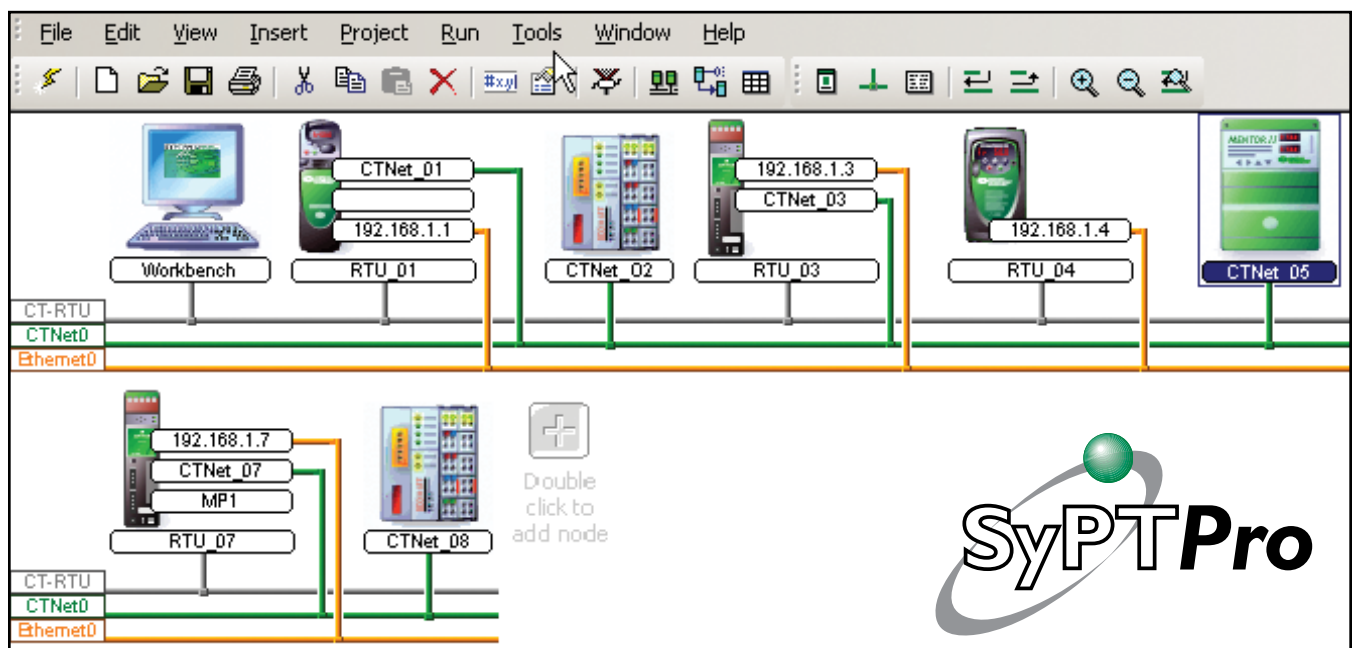

Connectivity

APPLICATION CO-PROCESSOR PLATFORMS

SM-Applications Plus / MD29AN / Digitax ST-P

SM-Applications Plus Unidrive SP, MD29AN (Mentor II / Quantum III) plug-in co-processors, and integrated in the Digitax ST-P include the CNet high-speed peer-to-peer fieldbus to allow the modules to communicate with one another.

The CNet-equipped co-processors are based on a high performance microprocessor with up to 384 Kbytes of program storage and 80 Kbytes of variable storage for user applications. In addition to the CNet fieldbus, serial ports are available for RS485 communications. The co-processors also include a built-in counter-timer unit and a position controller capability.

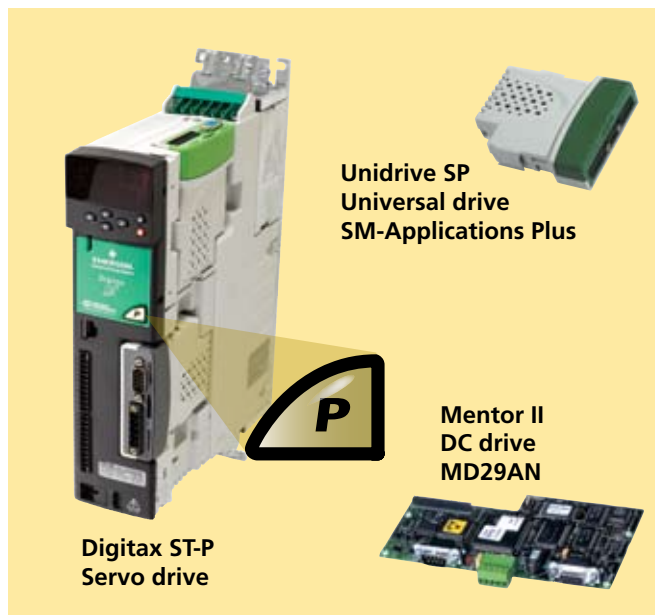

CTNET CABLE

Control Techniques supplies a high quality shielded twisted-pair cable suitable for high-speed data transmission. It is available in three standard lengths or any specified non-standard length.



Description	Order Code
100 meters	CTNet-100
Non-Standard (bulk in meters)	CTNet-xxx*

* XXX= number of meters

PC NETWORK INTERFACE CARD

For desktop and laptop computers, use the USB22-CNet network card. This interface card permits user specification of the node address, baud rate and IRQ (where applicable).



Network Application Card	Order Code
USB22-CNet	4500-0100

REMOTE I/O

The high-quality Beckhoff I/O system is available for CNet systems. Beckhoff systems for CNet include a bus coupler and a large variety of snap-on terminal blocks allowing up to 256 digital inputs or outputs and up to 100 analog inputs and outputs per bus coupler. Up to 64 Beckhoff I/O systems can be attached to a CNet network. I/O points can be easily read or written. (Beckhoff I/O for other networks available.)



Description	Order Code
Beckhoff Bus Coupler	SSP7200-RevD

Contact Control Techniques for details on the range of Beckhoff Remote I/O options available, including:

- Digital input terminals in 5, 24, and 48 VDC, 120 VAC
- Digital output terminals 5 and 24 VDC, Relay Output (115-400 VAC)
- Analog input and output terminals for a wide array of applications. All standard voltages, mA, RTD, thermocouple, etc.

NETWORK ACCESSORIES

Repeaters

For extending CNet cable segments and creating star topologies, there are three types of repeaters available:



Description	Order Code
Two-output (3-port) Repeater (Hub)	CTNet-Hub-Rev D
Twisted-pair to Fibre Optic Repeater	CTNet FIB-Rev D
Hybrid Hub for connecting previous versions of CNet hardware to current versions	CTNet Hybrid Hub

HMI OPERATOR INTERFACE

CTNet Modbus function codes

CTNet Modbus function codes allow the operator interface to access any Control Techniques drive connected to CTNet network via a standard RS485 serial connection. In the example below the operator panel is connected at a high-baud rate to the drives serial port and can obtain drive parameters from any of the drives on the three CTNet networks. This is possible using special Modbus function codes that pass the data through the drive to the CTNet network. This gives significant cost reductions and allows the operator panel to be a standard-off-the-shelf model with no additional hardware

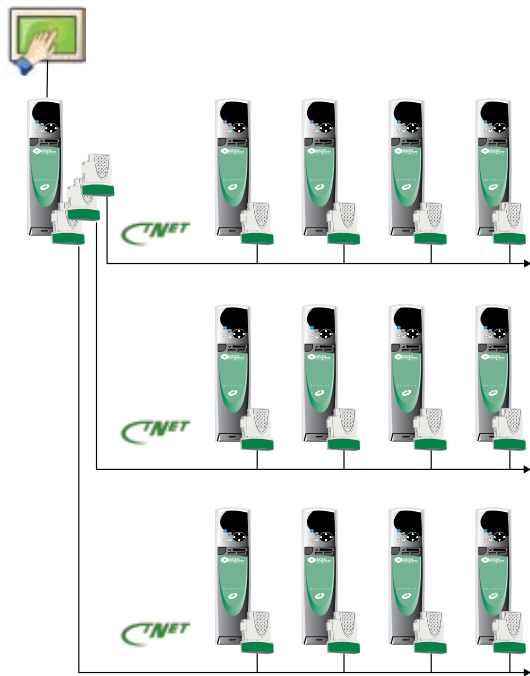

SyPTPro SYSTEM PROGRAMMING TOOLKIT

• Auto Detection

- When is connected to your drive system it will:
- Automatically interrogate your network
 - Discover which components are connected
 - Let you upload to the PC the software from the option modules

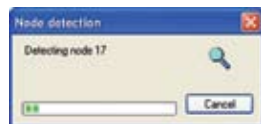

• Simplicity of Connection

SyPTPro may be connected via CTNet using a USB adapter direct to the CTNet network or through the standard RJ45 programming port on the drive. In both cases you get total visibility of the complete CTNet network for programming and diagnostics.

• Multiple - CTNet Networks

For the ultimate multi-tasking and multi-processing fit multiple SM-Applications Plus modules to your Unidrive SP or Digitax ST-P, this allows you to increase the processing power where required, and support multiple CTNet networks in a system. Even if you do not need to now, it is reassuring to know that you can expand your drive system to incorporate any future modification.

• Multi-point Programming

More than one programming station may be resident on a CTNet network allowing work to be done on different parts of the system simultaneously and so allowing commissioning times to be minimized.

NETWORK BRIDGES

The Unidrive SP provides unrivaled fieldbus flexibility. In addition to the standard Modbus RTU port, up to three fieldbus option modules can be installed in the Unidrive SP's option slots. This provides the capability to control and monitor a Unidrive SP on multiple fieldbus networks. For example, a single Unidrive SP can be configured to communicate on both DeviceNet and Profibus networks simultaneously.

In the example shown, CTNet is used to provide real-time coordination between two Unidrive SP modules. The DeviceNet and Profibus connections allow data to be passed to the controllers in a machine line.

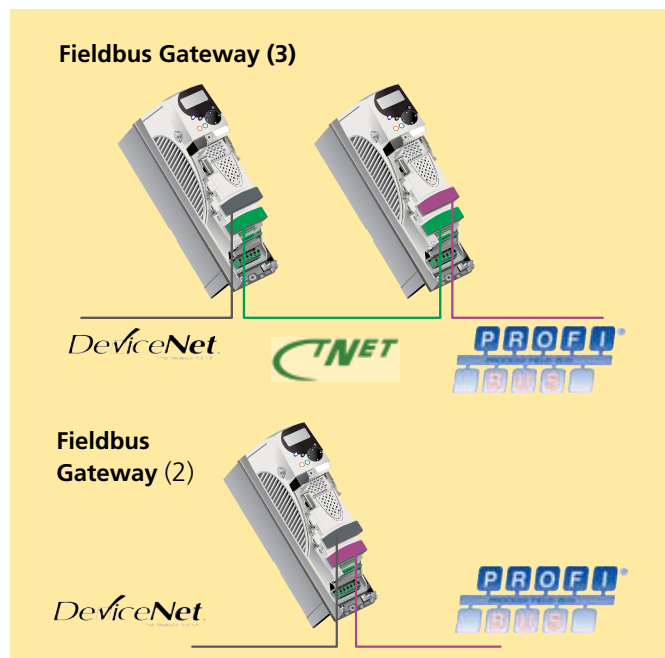



CTSync is a high performance communication link that can improve your machine's performance and reduce the cost of your control system. CTSync is standard with SM-Applications Plus. It provides synchronization between drive control loops thus allowing the creation of a virtual master reference.

TRADITIONAL MASTER / FOLLOWER SYNCHRONIZATION

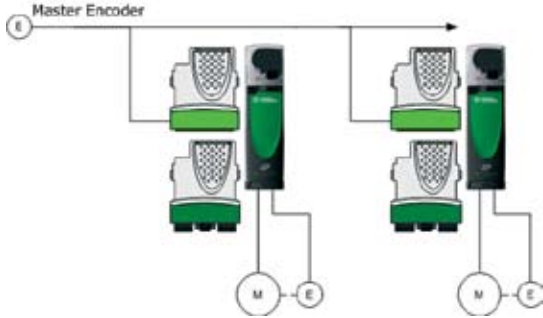

USING A VIRTUAL MASTER REFERENCE:

Example: Motion control with 4 axis linear interpolation

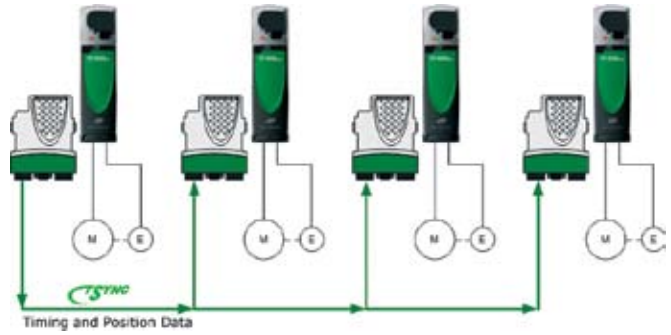

DISADVANTAGES OF TRADITIONAL MASTER / FOLLOWER:

- High resolution Sin/Cos encoders cannot be multi-dropped
- Difficult connections required for many encoder types, minimum of 6 wires
- Expensive encoder options required on every follower
- Drives software and control loops not synchronized between all drives preventing effective co-ordinated multi axis position control
- Not always possible to connect a master encoder

ADVANTAGES OF 'VIRTUAL MASTER':

- Co-ordinated multi-axis control with < 4 µsec jitter
- Solution for when a real encoder cannot be physically fitted to a machine
- Cleaner noise free signal for guaranteed performance
- Compensation with feed-forward
- Choice of encoder resolution
- Simple 2-wire connection



Drive Integration Automation Hierarchy Selection

It is rare that an industrial drive stands alone in an application. In the majority of cases, drives are part of a system. As such it is necessary for the parts of the system to communicate with one another, transmitting commands and/or data. This communication can be in many forms from traditional analog signals to wireless communication systems. Control Techniques produces lower cost, higher performance drives, with flexible and dynamic interfaces to products such as PLC's, HMI's etc.

Traditionally systems have been controlled by powerful Centralized Controllers at the Process Level. As the cost of PLC's reduced, control was distributed to the Machine level. As PLC's continue to fall in price, further distribution of control is happening. However, the threat to PLC's in this role comes from drives which have considerable processing power, and direct contact with much of the critical variables of the system thereby offering new opportunities in terms of optimized system control.

In all applications it is worth considering the relative benefits of Centralized and Decentralized Control. This assessment needs to be done prior to deciding on the most appropriate fieldbus for the application.

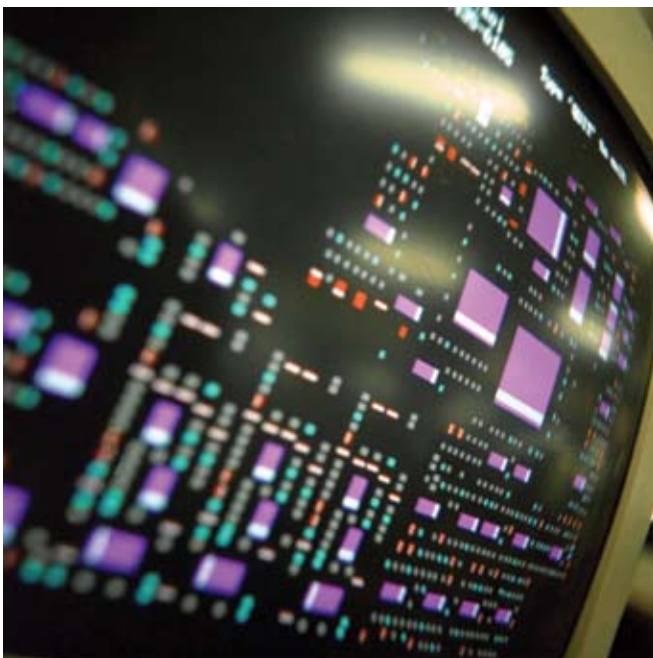

CENTRALIZED CONTROL SYSTEMS

Centralized control requires a powerful Machine Controller, (usually a PLC or PC) with centralized programming and configuring software tools to provide:

- Gateway to the process layer
- Machine co-ordination and sequencing
- Machine real-time control algorithms for one or a number of devices (including drives)
- A high speed and medium bandwidth communication system and/or support a lot of inputs and outputs for plant based devices
- Service data to and from devices

The communication throughout the system is via the machine fieldbus Local Area Network (LAN). The dynamic speed of such a network depends not only on the choice of fieldbus, but also on the number of nodes connected. Great care is needed in specifying such a system if the system requirements are not to be compromised. The specification of such a network is the most common problem during system commissioning, and can be responsible for some serious project delays.

A typical configuration for a centralized control system is shown below.

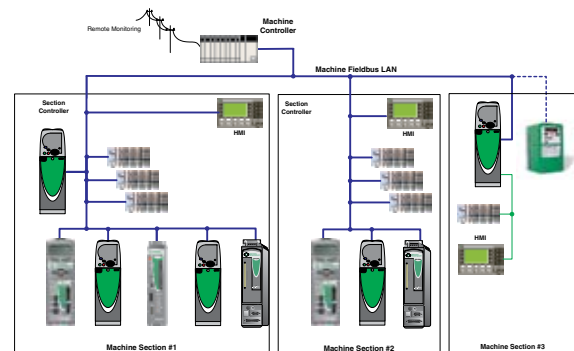

Advantages:

- Simple architecture
- One learning curve for programming and configuration tools
- Efficient, one point bridge to process layer
- Usually a lot of applications support available from controller suppliers and integrators

Disadvantages:

- Expensive hardware and software (Machine Controllers are expensive on large systems and software tools)
- The central controller is a commissioning bottleneck
- Redundancy is very expensive to build in
- A broad family of controllers needed for cost effective adoption across a factory

DECENTRALIZED CONTROL SYSTEM

This alternative approach is also referred to as a Distributed Control System. This requires:

- Peer to peer communications (devices to talk with one another)
- “Intelligence” in some devices
- A gateway to support the Process layer interfaces
- A common and flexible programming, configuration, commissioning and visualization software tool

Advantages:

- Low cost
- Small control panel size
- Easier design and maintenance – Modular software
- Opportunity for faster response times than with centralized control (Better Performance)
- Inherent system redundancy possible
- Multi-commissioning access reduces set-up time
- No machine controller
- Modular software readily facilitates re-use
- System is scalable

Fully Decentralized Control

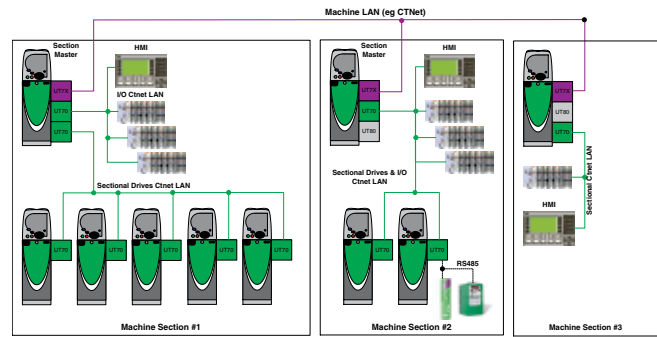

Disadvantages:

- Needs high level commissioning and programming tools (Need to realize sections and device functions)
- Gateway to Process layer required
- Process layer can access all machine devices (no filtering)
- High degree of system determinism may be required
- High system communication bandwidth may be required

HYBRID CONTROL SOLUTION

A Hybrid solution, sometimes known as Distributed Sectional or Cluster Control, is now receiving significant attention. This requires:

- A medium processing power Machine Controller to provide:
 - Gateway to the Process layer
 - Machine co-ordination and sequencing
 - Support a lot of system inputs and outputs (digital and analog) – High Speed and medium bandwidth to and from each section
- A medium processing power Sectional Controller to provide:
 - Gateway to the Machine controller
 - Section co-ordination, sequencing and if necessary synchronisation
 - Support a lot of system inputs and outputs (digital and analog) – High Speed and medium bandwidth to and from each section. Service data to and from each device
 - Master-Follower or Peer-Peer architectures can be adopted
 - Common programming, configuration and commissioning software tools

Hybrid Control (Distributed Sectional Control)

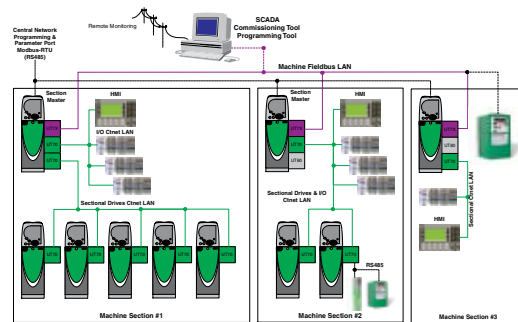

Advantages:

- Very cost effective solution for medium/large systems
- Simple architecture – each section controller is responsible for its own sectional devices
- Efficient, one point bridge to the Process layer
- Modular software – Easier development, maintenance and re-use
- Common server and marshalling
- Inherent sectional redundancy
- Multi-commissioning access
- Tight control with fast updates for Sectional control
- Common programming and commissioning software

Disadvantages:

- Potentially higher cost for small systems
- Without common software tools system (machine and sectional) visibility is restricted – solved with SyPTPro

Drive Integration Automation Hierarchy Selection (continued)

Having looked at these system implementations the opportunity for 'solutions platform' drives emerges. No single control configuration can be considered "the best" for all occasions the driving factor is the application itself. In the illustrations, there is not a wide proliferation of PLC's, indeed their absence is striking. In the decentralized and hybrid solutions however, there is a considerable requirement for decentralized "intelligence", and this is contained within Unidrive SP.



In the hybrid solution, the drive acts as both a communications bridge (linking the Machine fieldbus LAN to the Sectional LAN) and as the sectional controller. It also provides a further LAN to interface with the Sectional I/O. Further sub-LANs are also illustrated. This layering of LANs greatly simplifies the communications network and leads to great benefits in terms of system performance and visibility. The design is simplified by breaking the tasks into modules. This modular design lends itself to the important practice of re-use both of software but also hardware.

System performance is enhanced by tight synchronization of control loops and between the Unidrive SP and its option modules.

The capability of the Unidrive SP to undertake real-time control functions is critical. For example a winder-unwind controller may need to be embedded or a complete elevator control including call handling, speed/acceleration ramps, positioning etc. Windows™-based software tools (based on IEC61131-3) makes programming, commissioning and maintenance a straight forward task for operators familiar with PLC programming.

In all solutions, the need for the Unidrive SP to support modern high speed fieldbus communications is implicit.

ULTIMATE FLEXIBILITY

The flexibility of the Unidrive SP together with the option module range makes it the perfect Solutions Platform for any automation system.

The SM-Applications option modules can be used in almost unlimited combinations with fieldbus and I/O options in order to neatly dovetail into existing automation systems.

Alternatively, when starting out with a clean sheet of paper, the Unidrive SP can achieve the necessary cost and space savings by allowing the Project Engineer to accurately match the PLC and I/O requirements.

